



need for an uniform current distribution on the cathode, and long charging times are eliminated.

Using a Dewar-type electrochemical cell/calorimeter, it was shown that the rates of excess enthalpy generation using electrodes prepared by the Pd/D co-deposition technique were approximately 40% higher than that obtained when Pd bulk electrodes were used<sup>4</sup>. Positive feedback and heat-after-death effects were also observed with the Pd/D co-deposited electrodes. Infrared imaging of electrodes prepared by Pd/D co-deposition show that the working electrode is hotter than the solution indicating that the heat source is the Pd/D co-deposited electrode and not Joule heating. The IR imaging showed that the heat generation is not continuous, but occurs in discrete spots on the electrode. The steep temperature gradients of the hot spots indicated that the 'hot spots' observed in the infrared imaging experiments suggest that 'mini-explosions' were occurring, which was verified by using a piezoelectric transducer as the substrate for the Pd/D co-deposition. The claim that excess enthalpy generated in the cells

Pd/D//D<sub>2</sub>O, Li<sup>+</sup>, Cl<sup>-</sup>//Pt in amounts hundreds of times greater than can be delivered by any known chemical reaction/process, constituted proof of its nuclear origin. To verify that the heat generation is indeed nuclear in origin, nuclear ash needs to be detected. Measurements of X-ray emission, tritium production, transmutation and particle emission were explored. In early experiments, exposure of photographic film was observed that was indicative of the emission of soft X-rays<sup>5</sup>. Using Si(Li) X-ray and HPGe detectors, it was shown that the cathodically polarized Pd/D system emits X-rays with a broad energy distribution with the occasional emergence of recognizable peaks due to Pd K<sub>α</sub> and Pt L peaks<sup>5</sup>. Furthermore, the emission of X-rays was sporadic and of limited duration. The evidence of tritium production was based on the difference between the computed and observed concentration of tritium in the liquid and gaseous phases<sup>6</sup>. It was shown that the tritium production was sporadic and burst-like. During bursts, the average rate of tritium production ranged between 3,000-7,000 atoms sec<sup>-1</sup> over a 24-hr period. Both the radiation emission and tritium production indicated that the reactions were nuclear in origin and that they occurred in the subsurface. Use of either an external electric or magnetic field was explored to enhance these surface effects. Results of these experiments are discussed.

## Results and Discussion

SEM analysis of a polarized Au/Pd/D electrode exposed to an external electric field showed significant morphological changes<sup>7</sup>. These changes ranged from minor, *e.g.*, re-orientation and/or separation of weakly connected globules, through forms exhibiting molten-like features. EDX analysis of one such feature, a crater, showed the presence of additional elements (Al and Mg) that could not be extracted from cell components and deposited at discrete sites<sup>8</sup>. Furthermore it is thermodynamically impossible to electrochemically plate out metals such as Al and Mg from aqueous solutions. When the cell is placed in an external magnetic field, the Pd globules appear to be flattened with small protrusions extending in all directions, Figure 1a. This shape change is attributed to the action of Lorentz forces. New elements detected in the external magnetic field experiments include Al, Fe and Cr. To verify that the new elements observed on the

cathodes are nuclear in origin, the Pd/D co-deposition was done in the presence of a CR-39 detector. CR-39 is a polyallyldiglycol carbonate polymer that is widely used as a solid state nuclear track dosimeter chip. When traversing a plastic material such as CR-39, charged particles create along their ionization track a region that is more sensitive to chemical etching than the rest of the bulk. After treatment with an etching agent, tracks remain as holes or pits and their size and shape can be measured. It should be noted that, in the area of modern dosimetry, it is well recognized that CR-39 dosimeter chips are the most efficient detectors for the detection of light particles (alphas or protons)<sup>9</sup>. Experiments were conducted in which either a Ni screen or Au wire was wrapped around a CR-39 chip and was then used as the substrate for the Pd/D co-deposition. After the Pd was completely plated out, the cell was exposed to an external magnetic field. The experiment was terminated after eight days and the CR-39 chip was etched using standard protocols. After etching, the chip was examined under a microscope. Figure 1b shows an image of an area that had been damaged. Numerous tracks are clearly observed in the area where the Au wire was in contact with the CR-39 detector. This indicates that the source of the tracks is the cathode. The expanded view of the spot indicated shows a large number of tracks, Figure 1c. The number of tracks is far more than are observed in laser fusion experiments (typically DD or DT). Figure 1d shows an image that was taken near the edge of the cathode where the density of tracks is less. A number of double tracks are observed in this image. Such tracks are observed when a reaction emits two particles of similar mass and energy. Similar results were obtained for external electric field experiments.

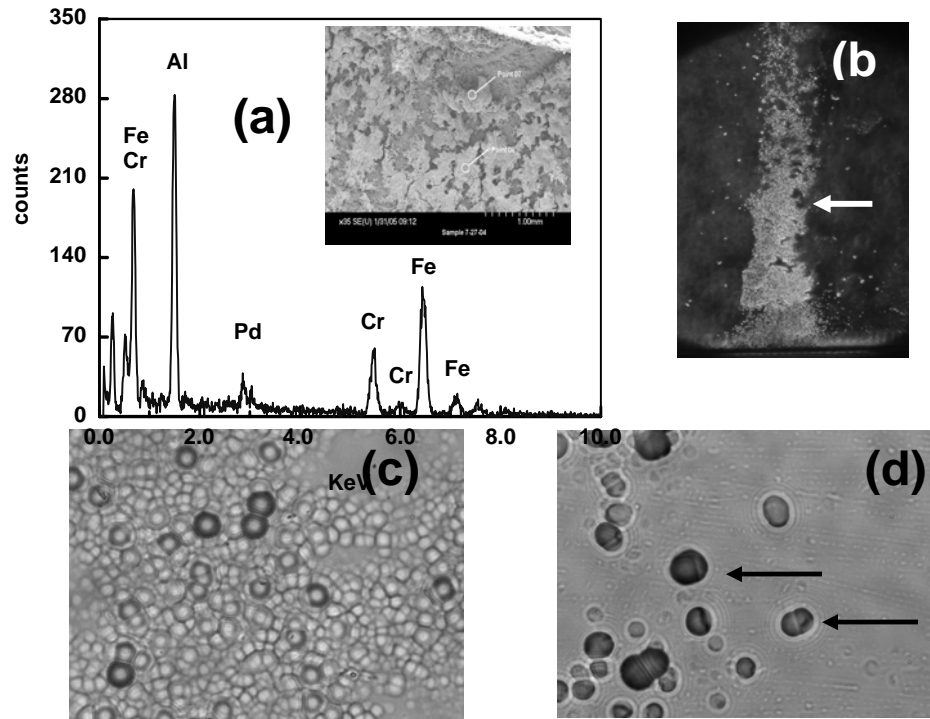

**Figure 1.** (a) EDX of the area indicated in the SEM of a star-like structure observed in a Pd/D co-deposited film exposed to an external magnetic field. The Pd/D co-deposition was done on Au foil. (b) 20X magnification of cloudy area observed where the Au/Pd/D cathode was in contact with the CR-39 detector during an external magnetic field experiment. (c) 500X magnification of area indicated by arrow in Figure 1b showing a high density of tracks. (d) 500X images taken near the edge of the Au/Pd/D cathode where the density of energetic particles is less. Arrows indicate double tracks.

In conclusion, a method of reproducibly producing new elements and high energy particles is described. In this method, the cathode prepared by the Pd/D co-deposition process is placed in either an external electric or magnetic field. The observed morphology changes of the Pd globules, the presence of new elements and tracks due to high energy particles observed where the cathode was in contact with the CR-39 detector constitute definitive proof that nuclear activities occur within the Pd lattice. Investigations are ongoing to determine the nature of these nuclear processes. In order to fully exploit this system for energy production, an understanding of the processes responsible for the effect is needed to both initiate it and sustain it. Initial results suggest electron capture by the deuteron to form, what appear to be, low energy neutrons. These neutrons are then captured by other elements present in the sample matrix to form the new elements and high energy particles.

### Acknowledgements

This work was funded by the SPAWAR Systems Center San Diego ILIR Program.

## References

1. S. Szpak and P.A. Mosier-Boss, *Phys. Letts. A*, **221**, 141-143 (1996).
2. S. Szpak, P.A. Mosier-Boss, S.R. Scharber and J.J. Smith, *J. Electroanal. Chem.*, **337**, 147-163 (1992).
3. S. Szpak, P.A. Mosier-Boss and J.J. Smith, *J. Electroanal. Chem.*, **379**, 121-127 (1994).
4. S. Szpak, P.A. Mosier-Boss, M.H. Miles and M. Fleischmann, *Thermochim. Acta*, **410**, 101-107 (2004).
5. S. Szpak, P.A. Mosier-Boss and J.J. Smith, *Phys. Letts. A*, **210**, 382-390 (1996).
6. S. Szpak, P.A. Mosier-Boss, R.D. Boss and J.J. Smith, *Fusion Technology*, **33**, 38-51 (1998).
7. S. Szpak, P.A. Mosier-Boss, C. Young and F.E. Gordon, *J. Electroanal. Chem.*, **580**, 284-290 (2005).
8. S. Szpak, P.A. Mosier-Boss, C. Young and F.E. Gordon, *Naturwissenschaften*, **92**, 394-397 (2005).
9. V.R. Organessian, V.V. Trofimov, M. Danzyger, B. Dörschel, D. Hermsdorf and O.L. Orelovitch, *Radiation Measurements*, **40**, 32-26 (2005).

# **Pd/D Co-Deposition: Excess Power Generation and Its Origin**

**P.A. Mosier-Boss, S. Szpak, and F.E. Gordon**  
*SPAWAR Systems Center San Diego, Code 2373, San  
Diego, CA 92162*

**L.P.G. Forsley and G.W. Phillips**  
*JWK Technologies Corporation, Annandale, VA 22003*

**233<sup>rd</sup> ACS National Meeting and Exposition**  
**Symposium on New Energy Technology**  
**Chicago, IL**  
**March 25-29, 2007**

# Pd/D Co-Deposition

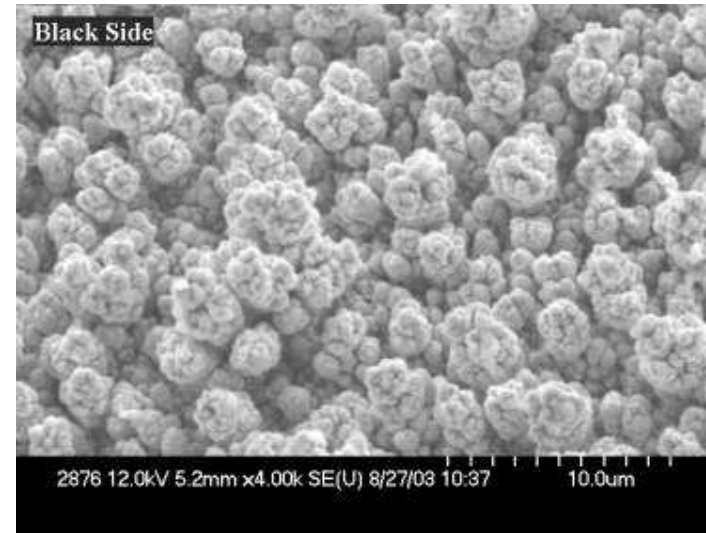
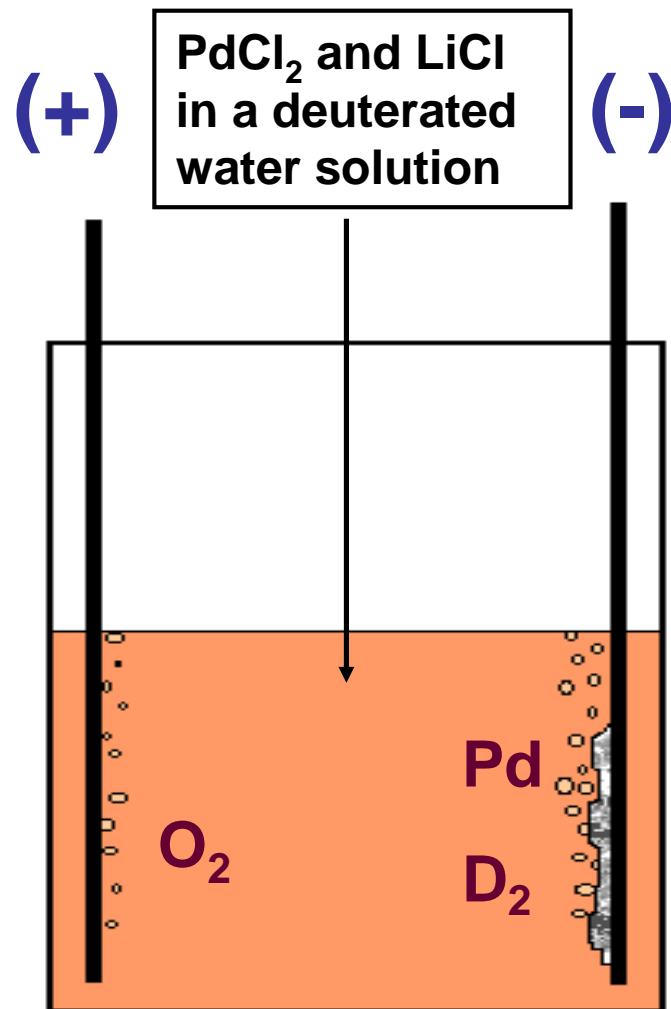

As current is applied, Pd is deposited on the cathode. Electrochemical reactions occurring at the cathode:



The result is metallic Pd is deposited in the presence of evolving D<sub>2</sub>

# Excess Enthalpy

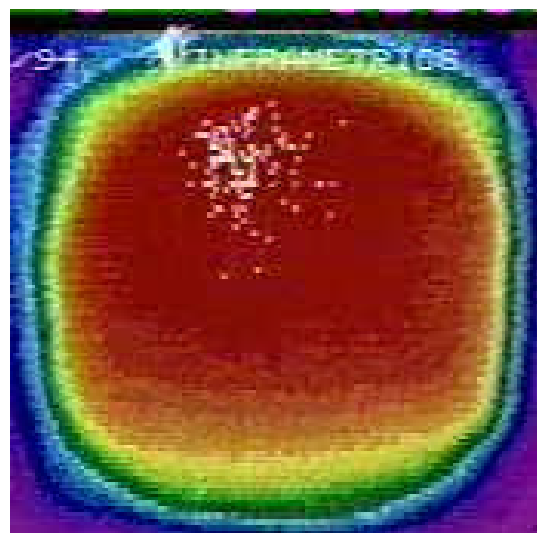
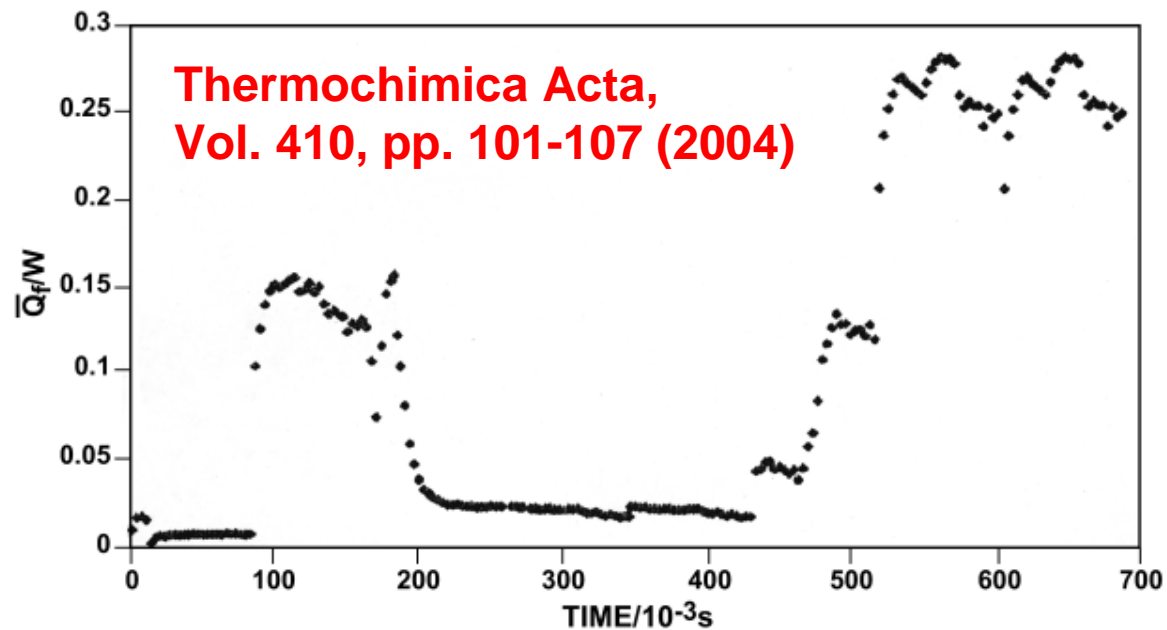
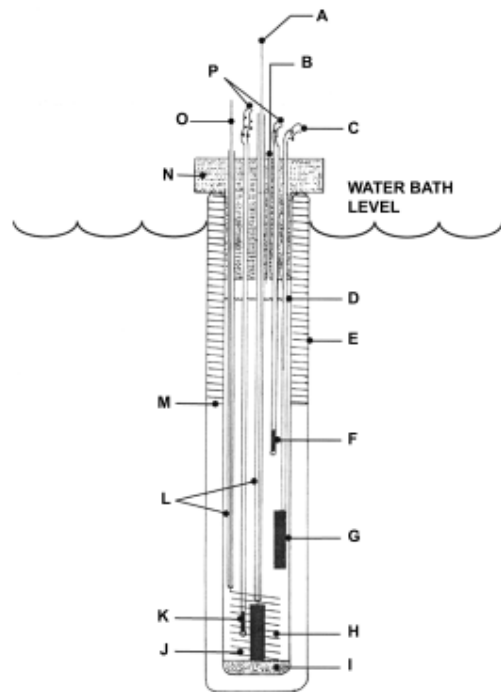

**Il Nuovo Cimento,  
Vol 112A, pp. 577-585 (1999)**

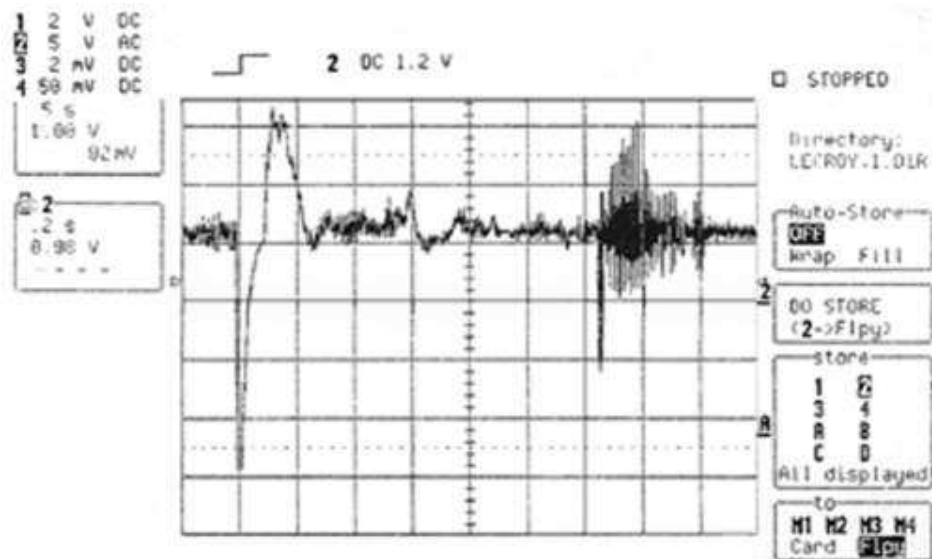



# Search for Nuclear Ash

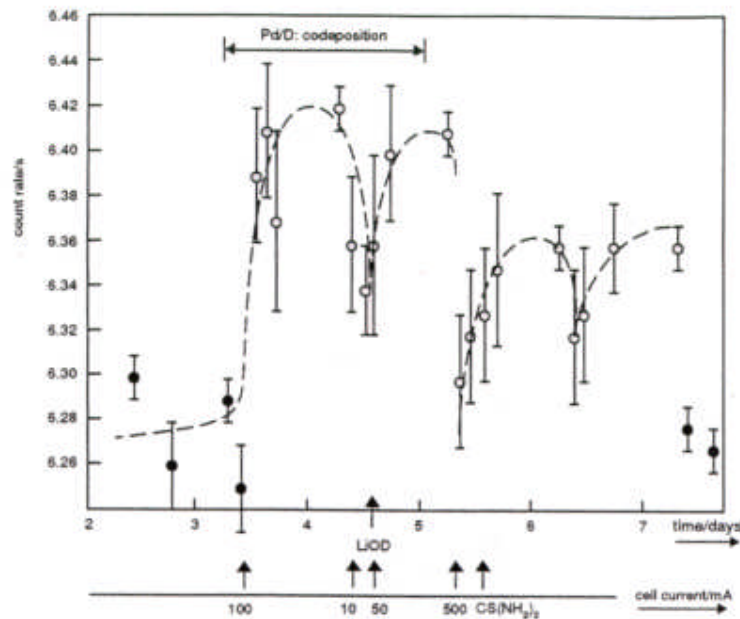
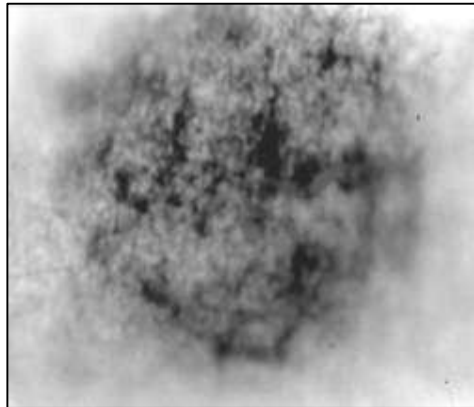

**Radiation emission**

**Physics Letters A, Vol. 210, pp. 382-390 (1996)**

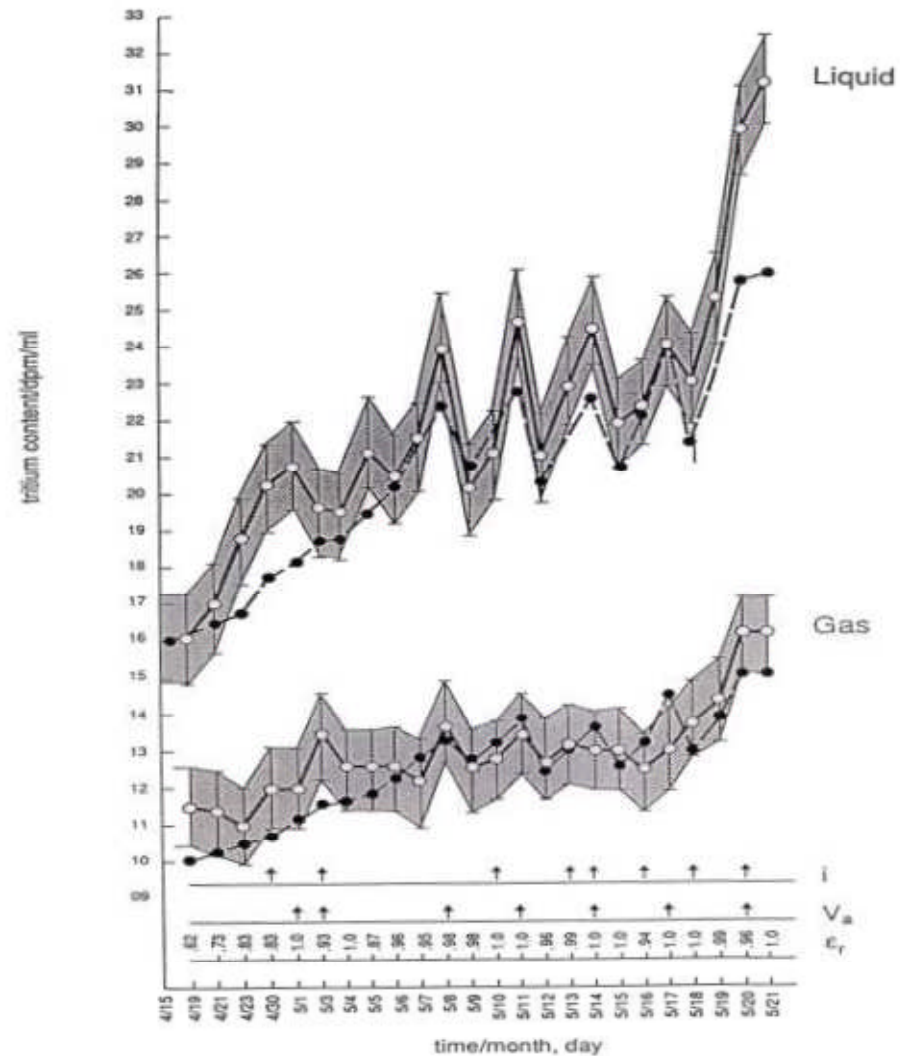

**Tritium production**

**Fusion Technology, Vol. 33, pp.38-51 (1998)**

# External Electric and/or Magnetic Field Experimental Configuration

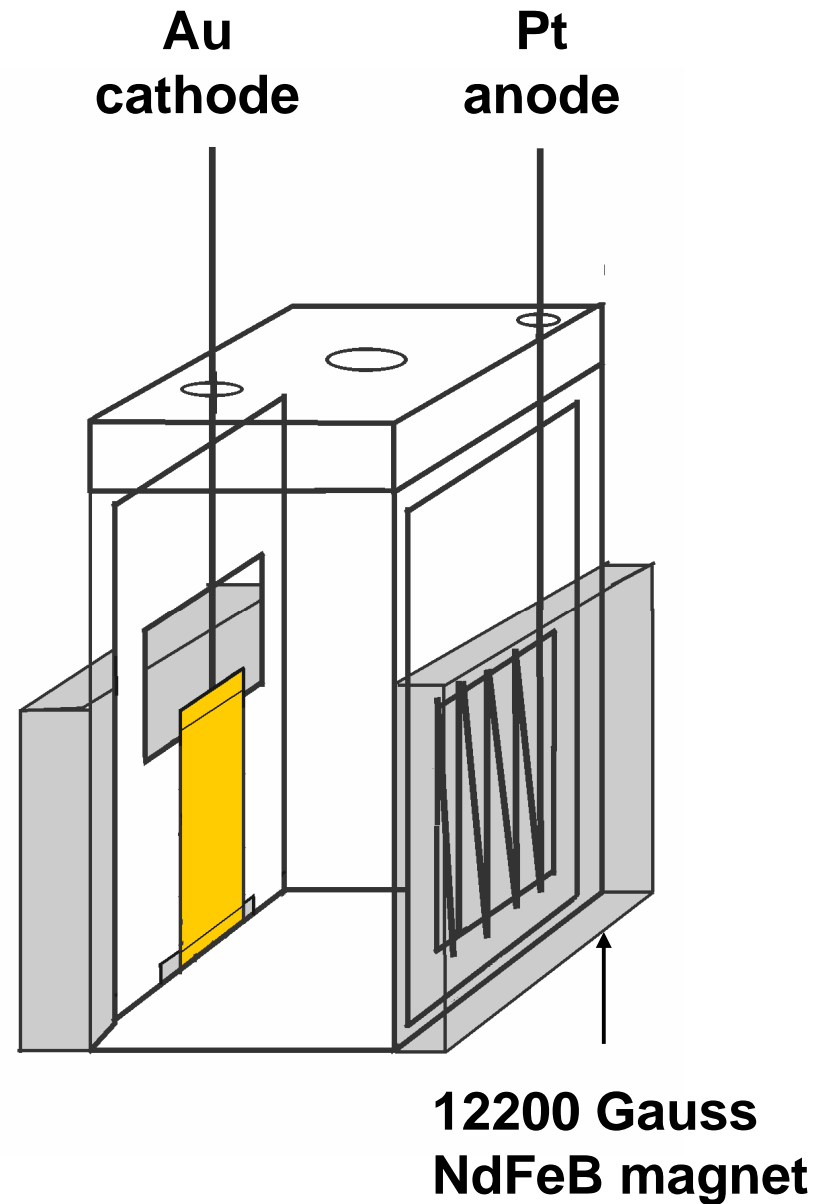
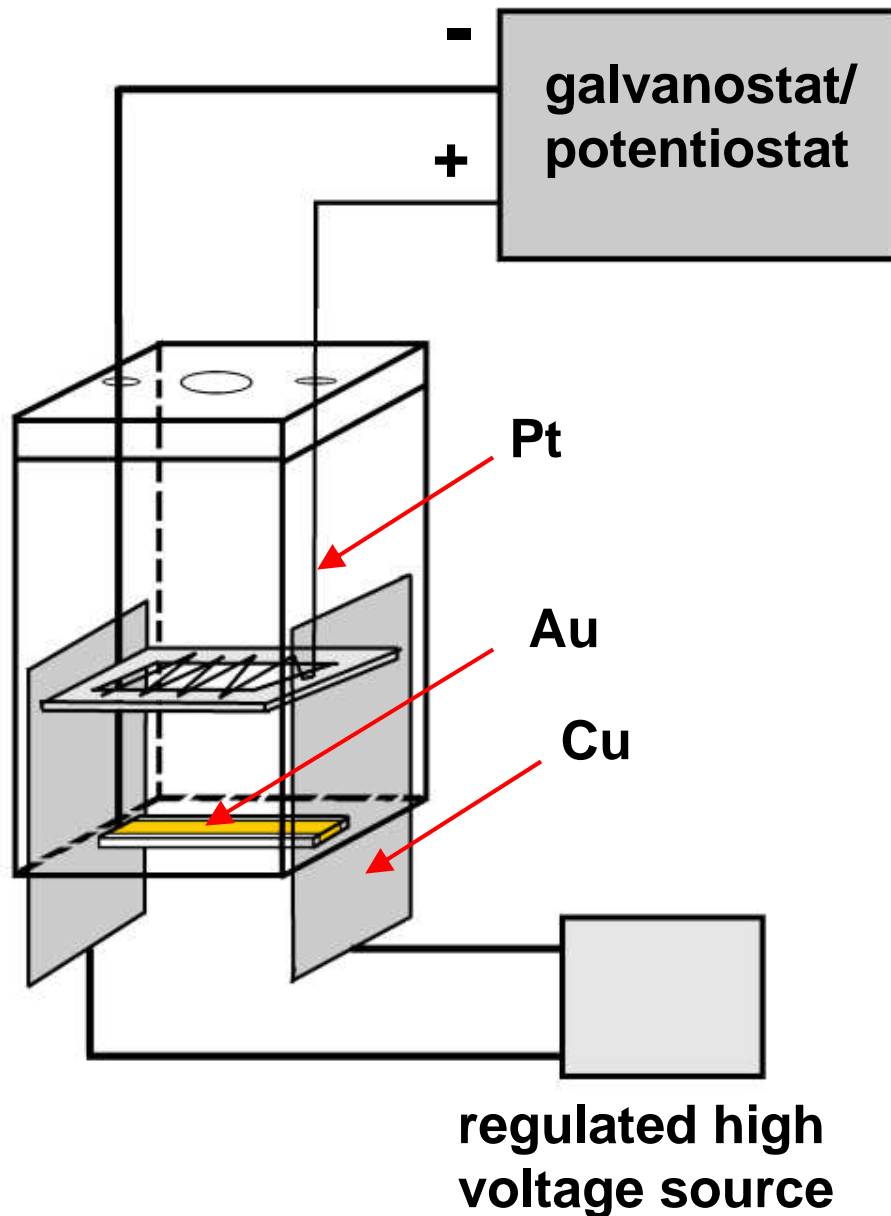

# E-Field Morphology Changes

**craters**

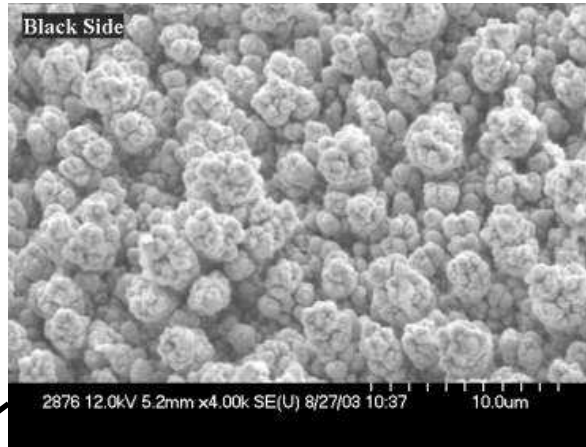

**production of dendritic growth**

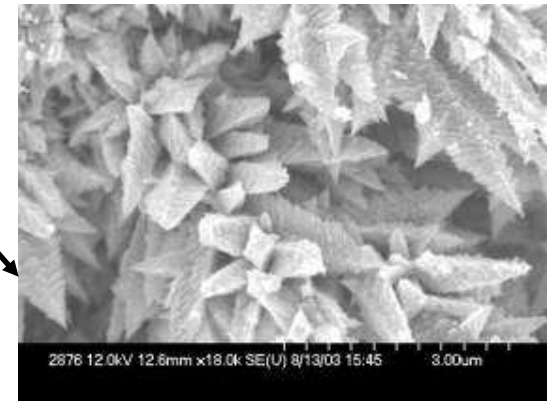

**absence of field:  
cauliflower-like  
morphology**



**long wires**

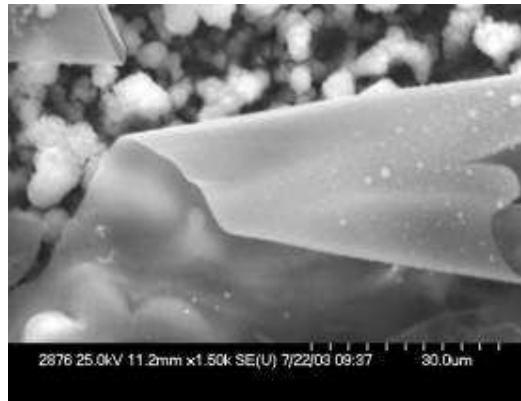

**folded thin films**

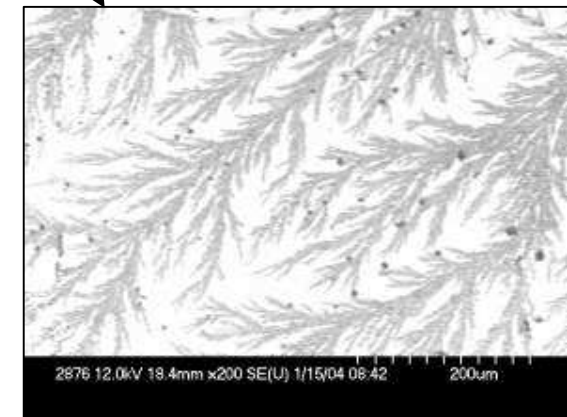

**formation of fractals**

# E-Field: Micro-Volcano-Like Features

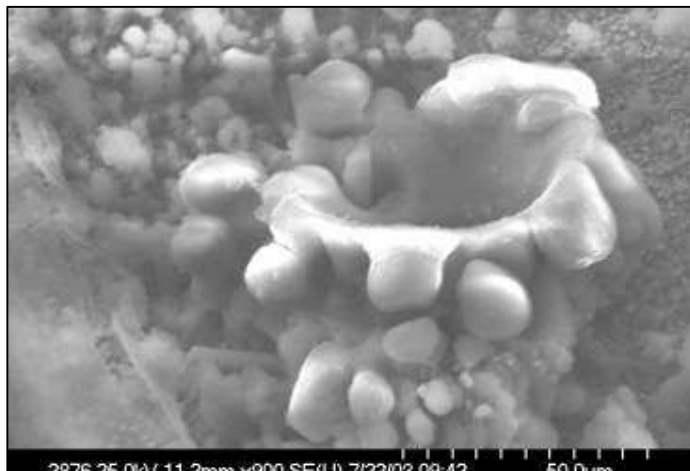
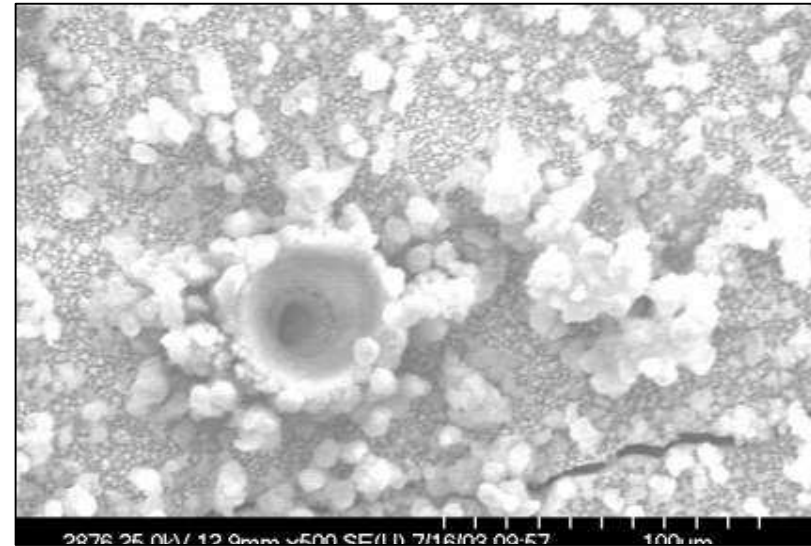
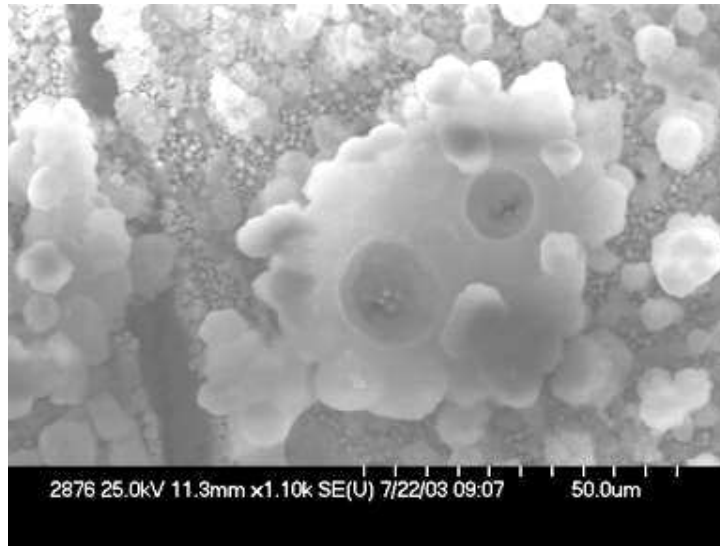

- Features suggestive of solidification of molten metal.
- Energy needed to melt metal is of a nuclear origin.
  - Should be reflected by chemical analysis of these features

# E-field: Chemical Composition of the Inside and Outside Rims of a Crater

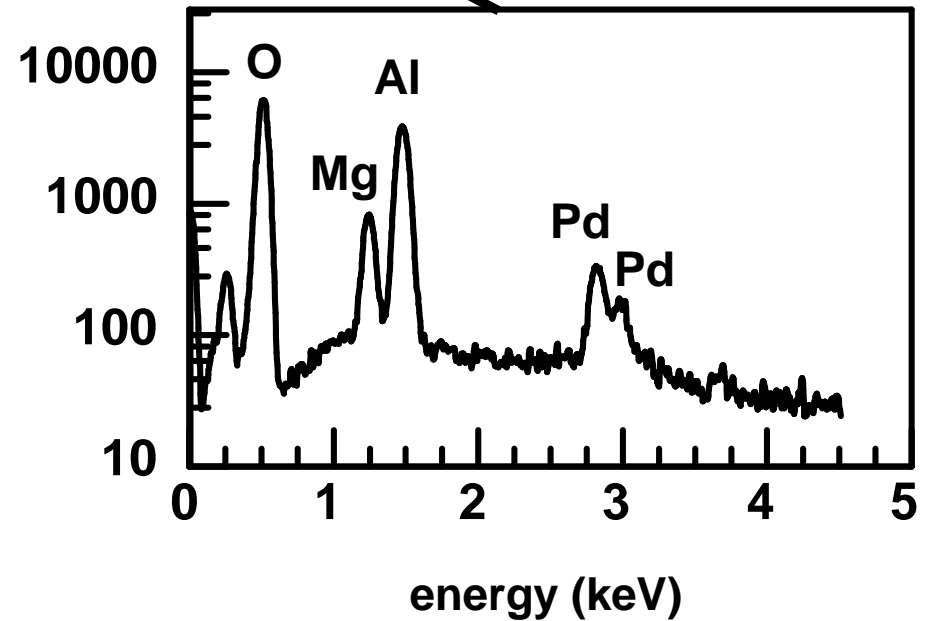
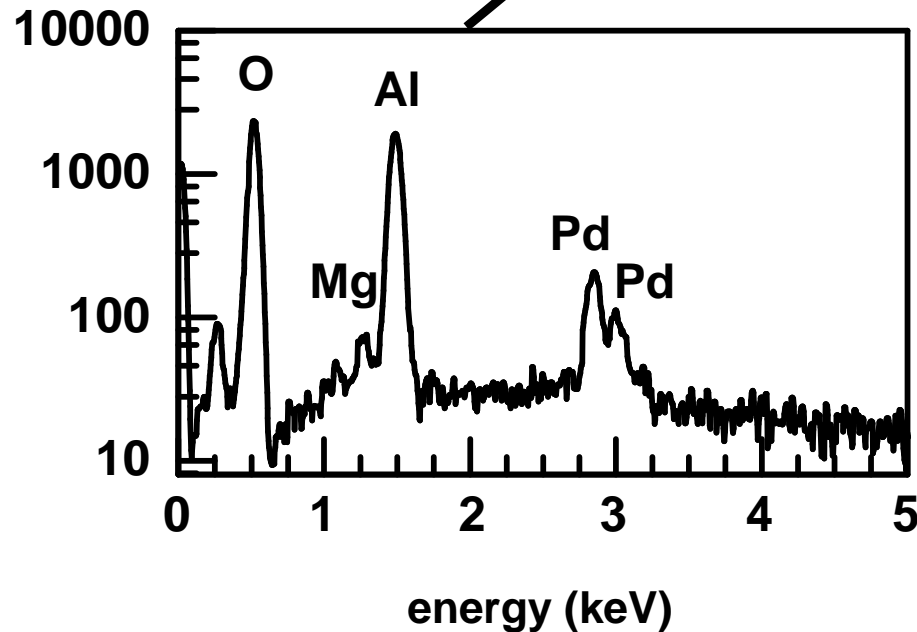
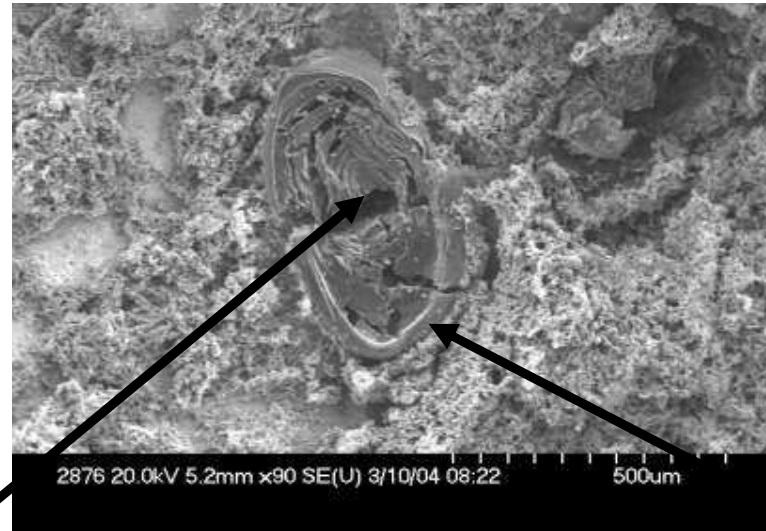

# Chemical Composition of Structures Formed in an Applied Magnetic Field

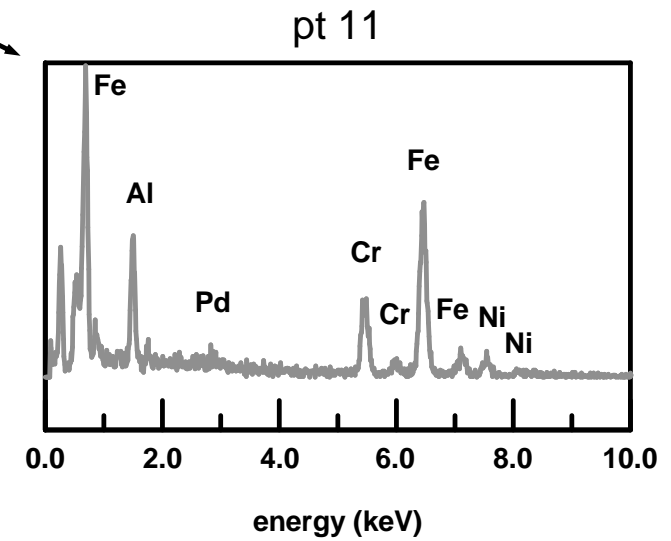
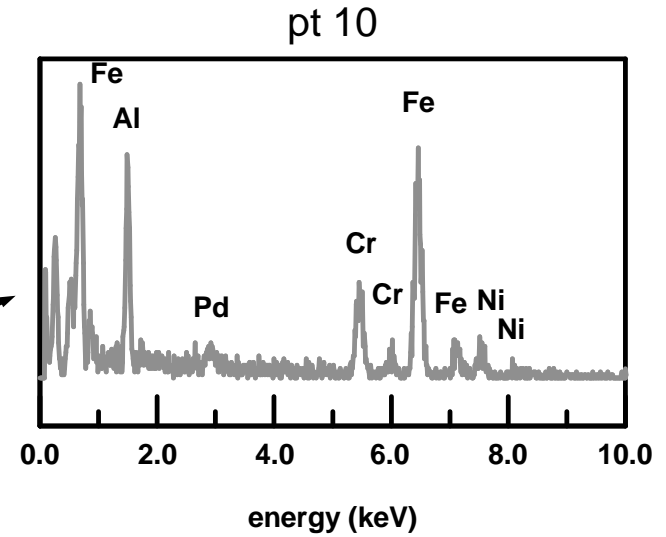
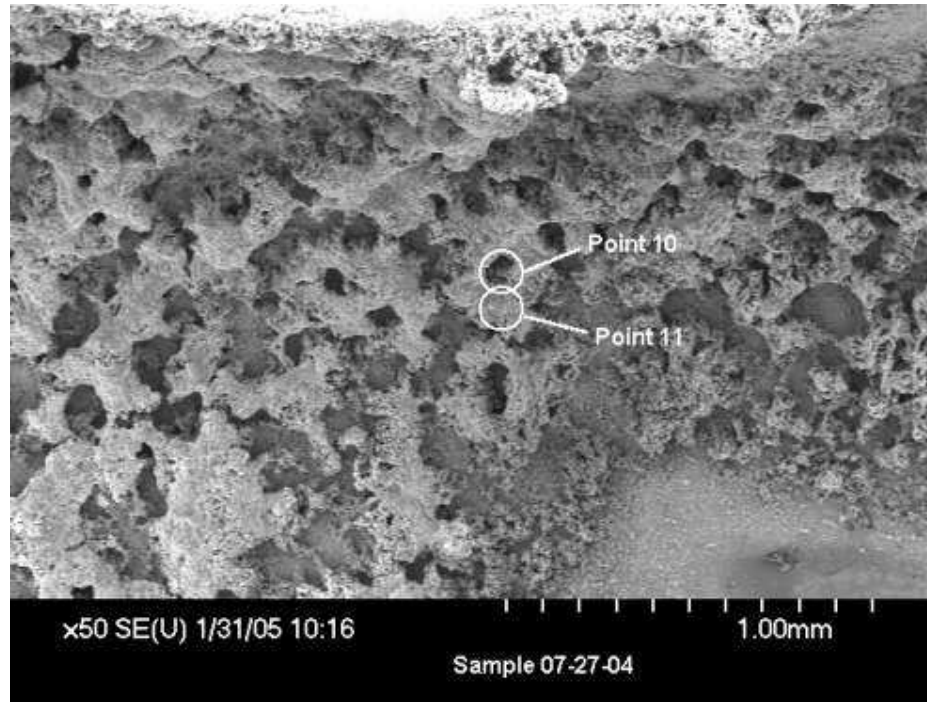

# How Can We Verify that the Observed New Elements are Nuclear in Origin?

- **SEM-SIMS: look for changes in the isotopic ratios**
- **Measure  $\gamma$  and X-ray emissions**
- **Detect particle emission using CR-39 chips**
  - **Easy to do**
  - **Inexpensive**
  - **Requires minimal instrumentation**
  - **Is a 'constant integration' method**
  - **No electronics**

# Particle Detection Using CR-39

- CR-39, polyallyldiglycol carbonate polymer, is widely used as a solid state nuclear track detector
- When traversing a plastic material, charged particles create along their ionization track a region that is more sensitive to chemical etching than the rest of the bulk
- After treatment with an etching agent, tracks remain as holes or pits and their size and shape can be measured.

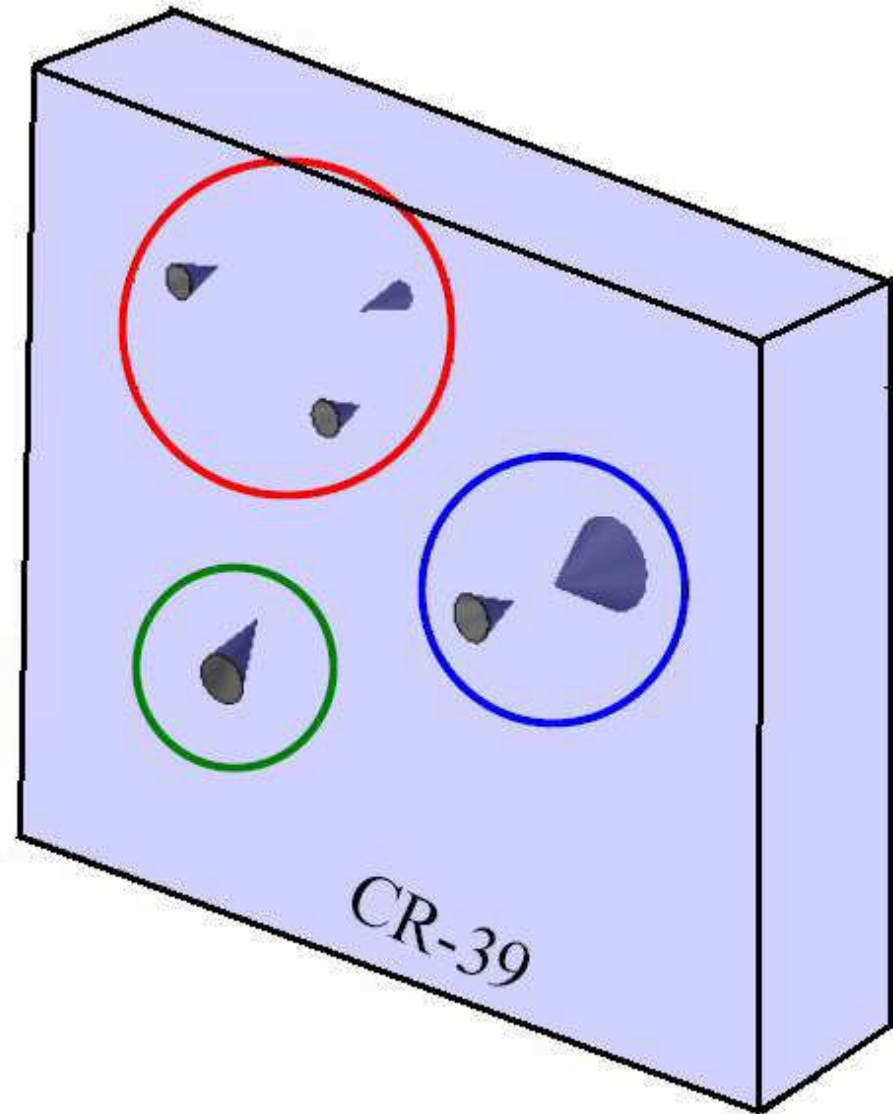



# Ag wire/Pd/D in Magnetic Field

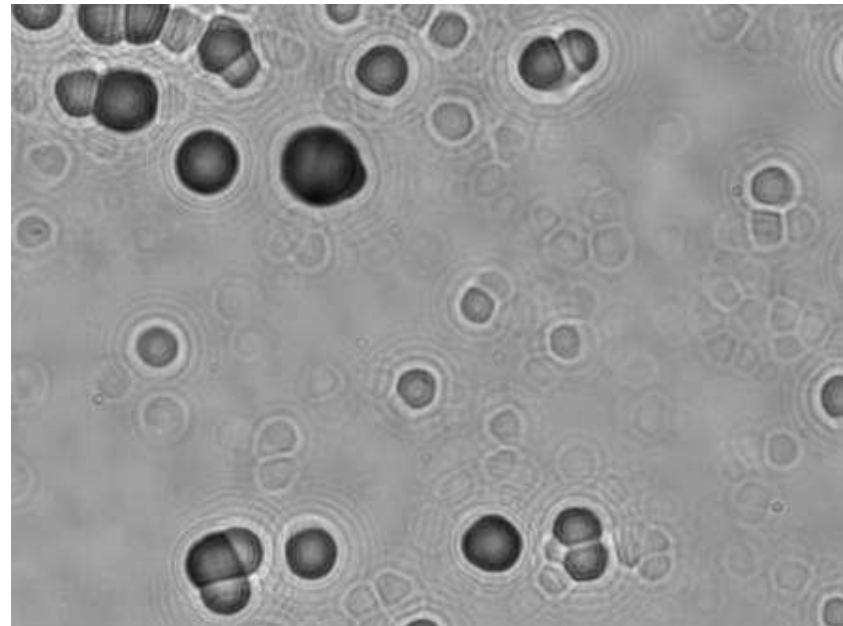
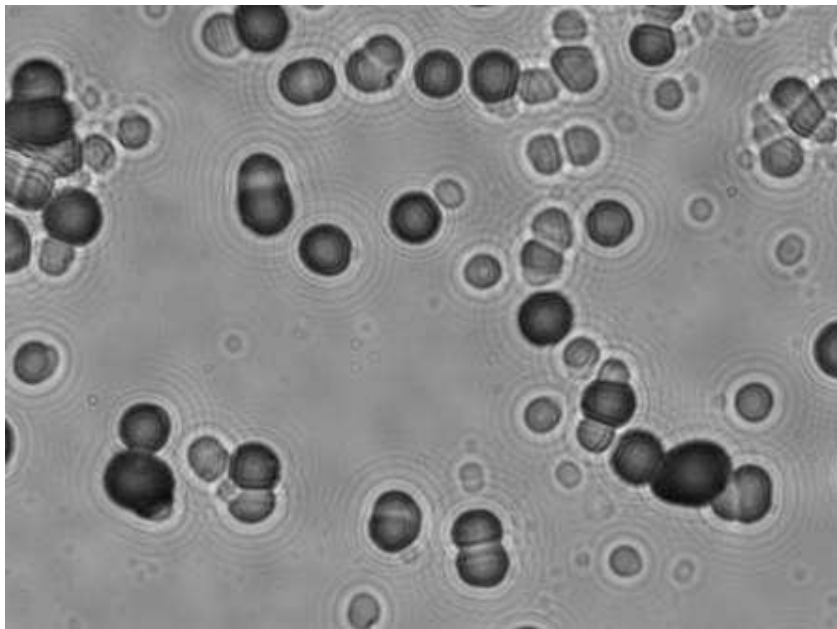
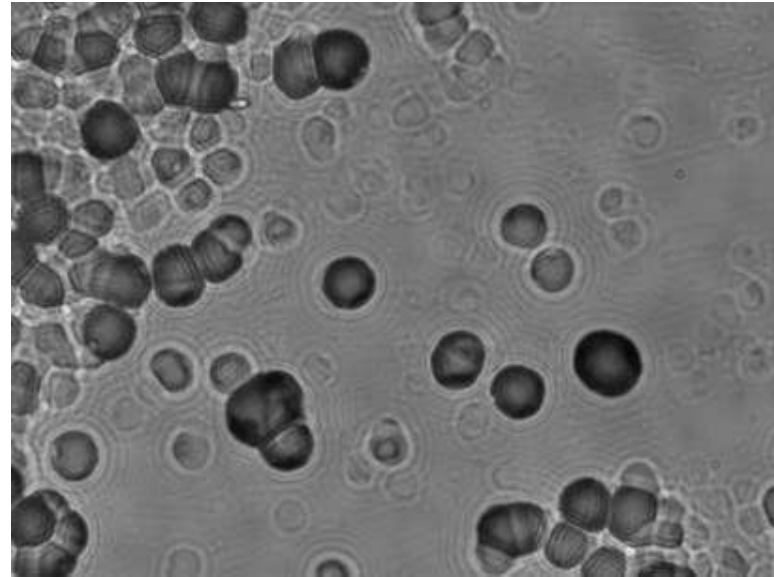
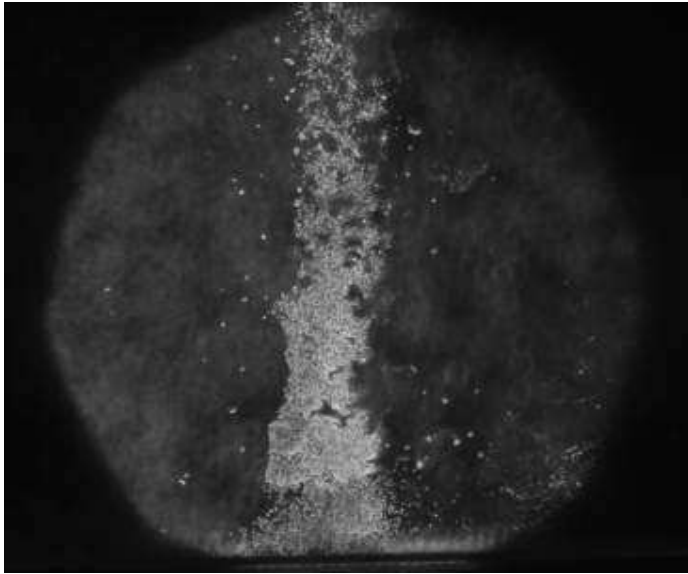

# Is a Feature Due to Background or to a Particle?

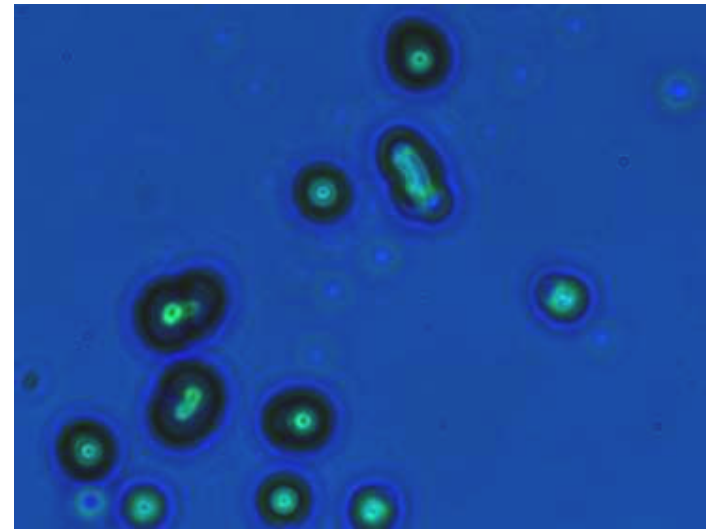
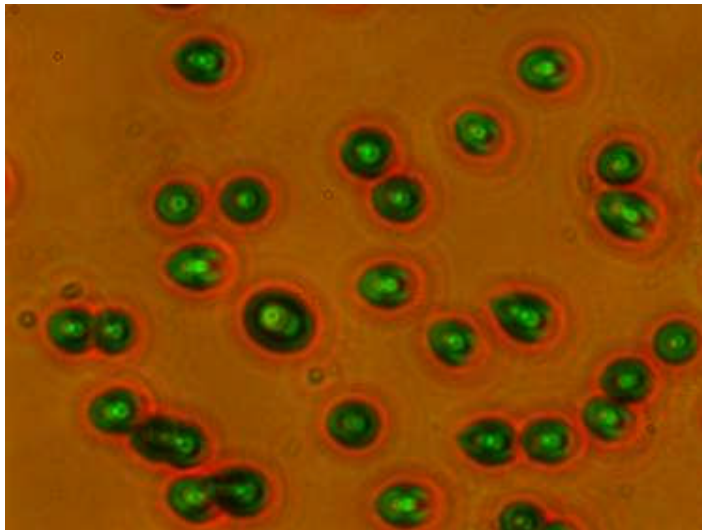
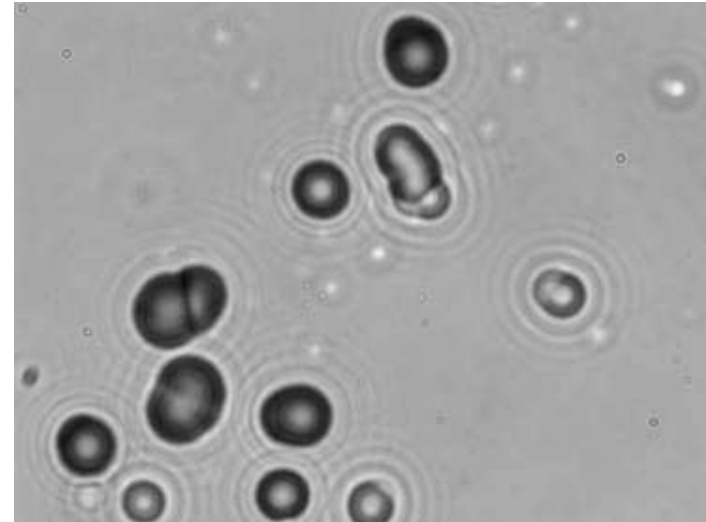
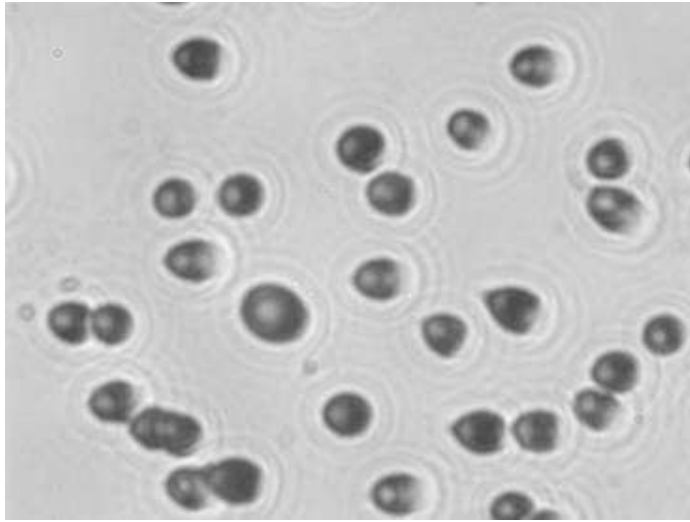

**Features due to background are small, bright and shallow (they refract light from the shallow, curved, bottoms causing them to be brighter when the microscope is focused on the surface features). The deeper nuclear tracks are darker. If you focus deeper into the chip they show bright points of light at their centers.**

# Summary of Control Experiments

- Pits are not due to radioactive contamination of the cell components
- Pits are not due to impingement of  $D_2$  gas on the surface of the CR-39
- Pits are not due to chemical reaction with electrochemically generated  $D_2$ ,  $O_2$ , or  $Cl_2$
- LiCl is not required to generate pits
- $D_2O$  yields higher density of pits than  $H_2O$
- Pd/D co-dep gave higher density of pits than Pd wire

# Front and Back Surface Comparison: 1 mm by 17 mm scan

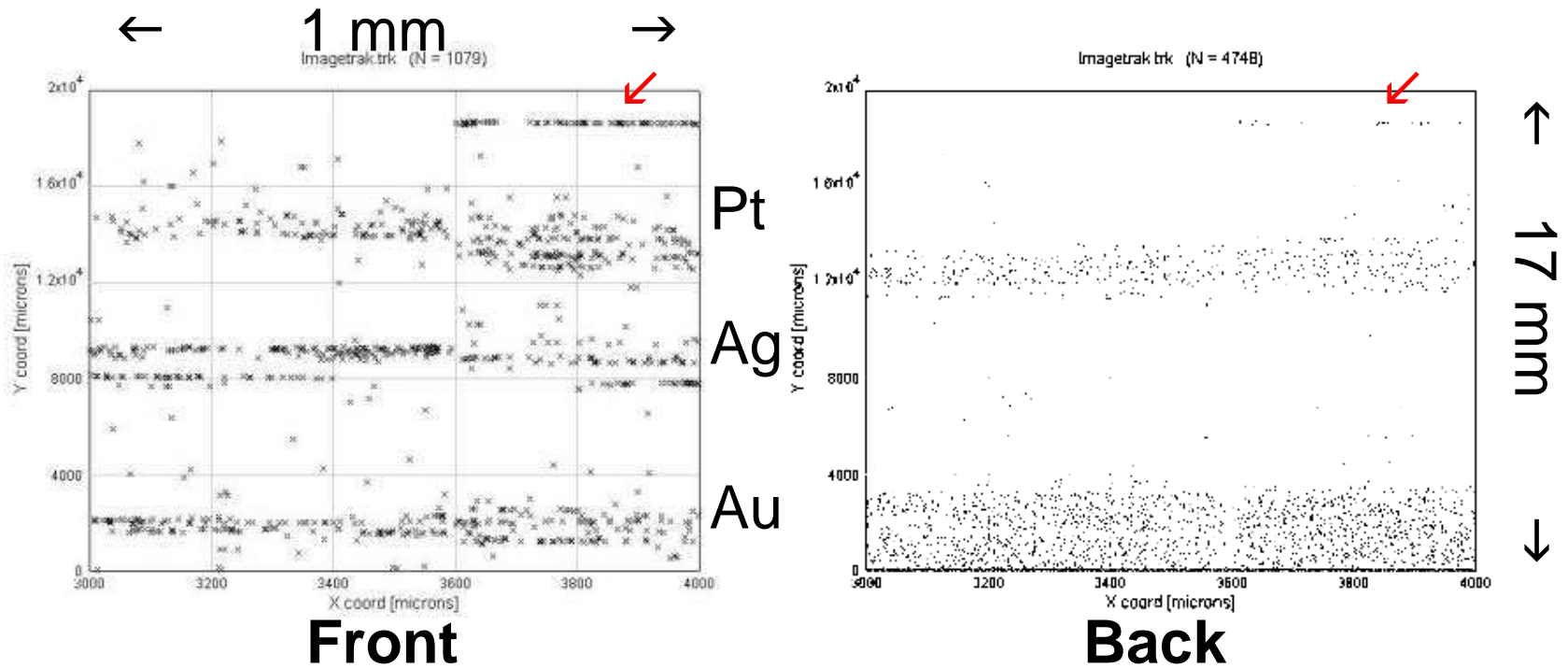

Same (x,y) locations, front and back.

↙ same feature seen on both sides for Pt wire.

Pt, Ag, Au tracks on front. Pt and Au tracks on back.

*No tracks from Ag on back!*

# Counts vs Major Axis

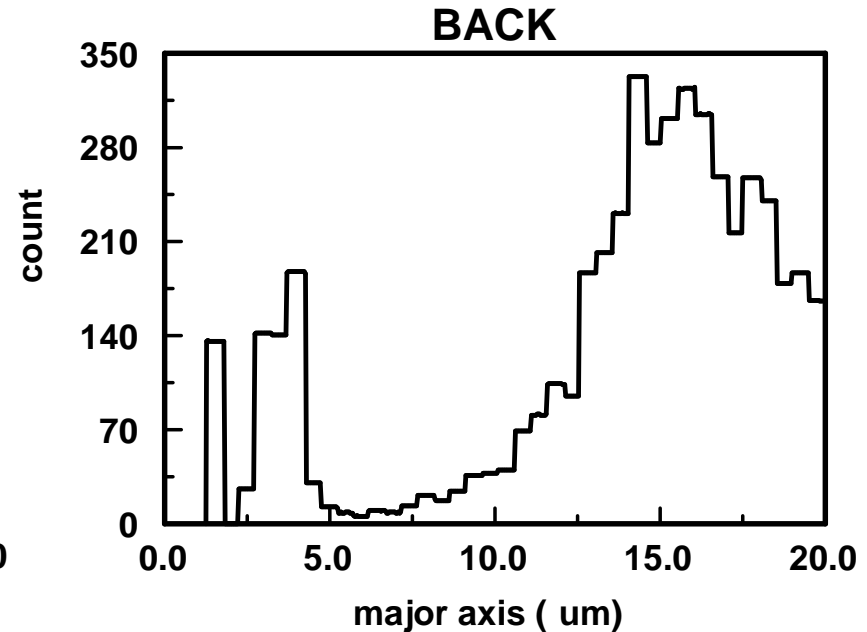
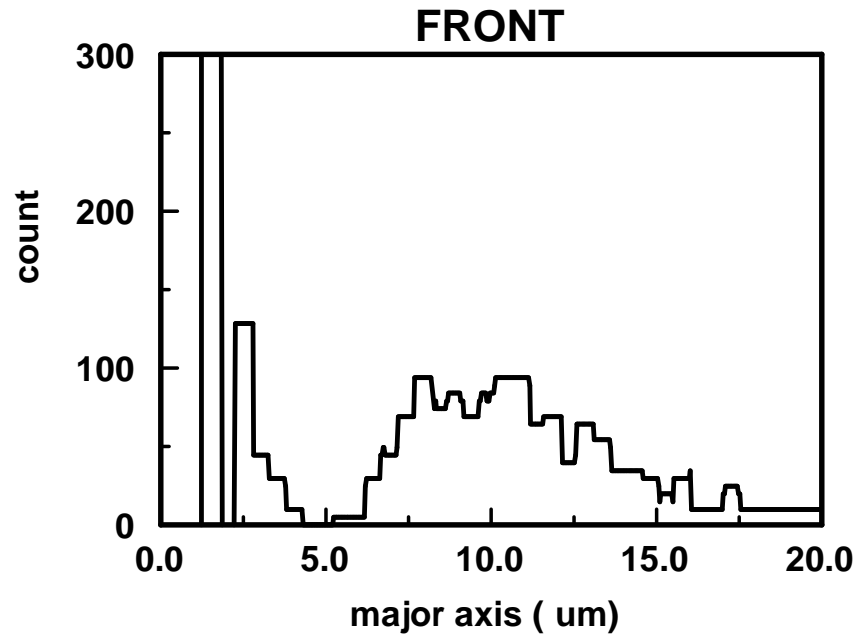

Front: d1, 2  $\mu\text{m}$ ; d2, 3.5  $\mu\text{m}$ ; d3, 8 - 12  $\mu\text{m}$

assignment >4.2 MeV  $\alpha$ ?

Back: d1, 2  $\mu\text{m}$ ; d2 3.8  $\mu\text{m}$ ; d3, 12 - 20+  $\mu\text{m}$

assignment >40 MeV  $\alpha$ ? >10 MeV  $p^+$ ? Neutrons?

# Neutron Track Size

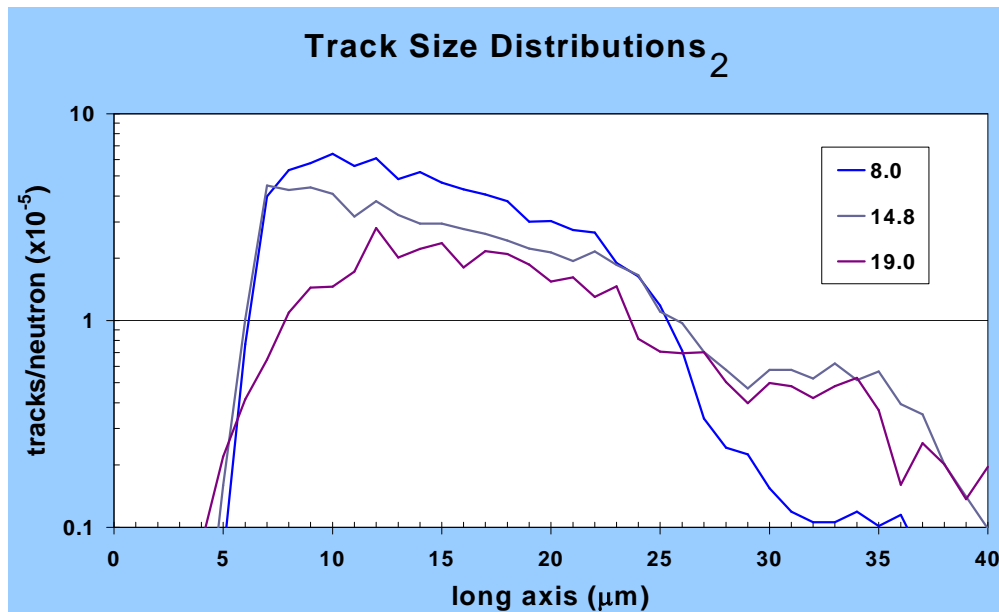
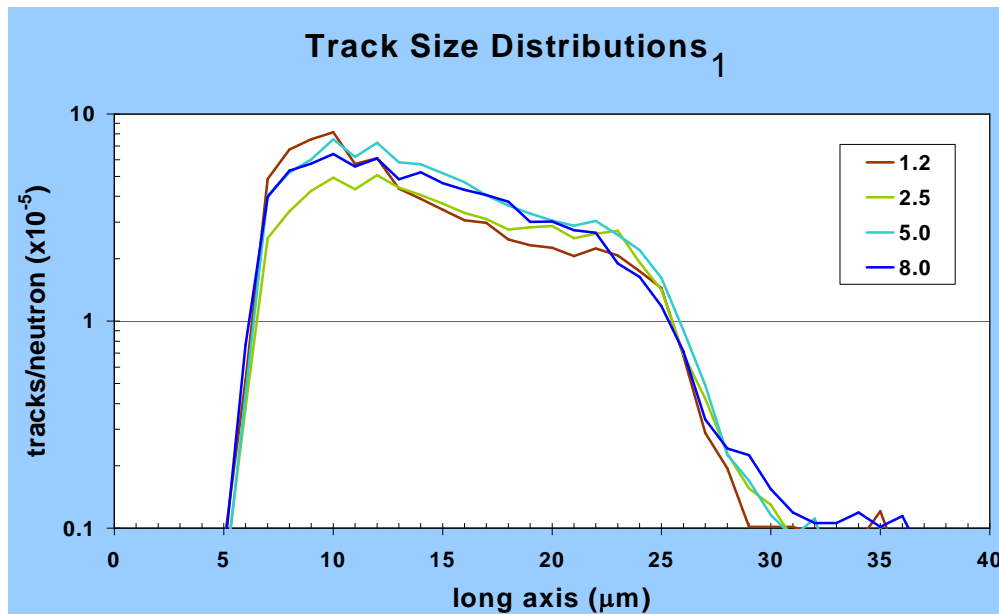

CR-39 n efficiency  $10^{-4}$  -  $10^{-5}$

n tracks caused by knock-ons with CR-39 atoms:



$n_e > 12$  MeV will break  ${}^{12}\text{C}$  into  $\alpha$  particles, leaving a “triple” track.

These  $\alpha$  particles will have little momentum and won't move.

Uniform number of knock-ons throughout CR-39 thickness due to low neutron stopping power.

Track size function of  $n_e$ .

Adjacent plots show  $n_e$  range from 1.2 MeV to 19 MeV.

<sup>1,2</sup> Phillips, *et. al.*, “Neutron Spectrometry Using CR-39 Track Etch Detectors”, *14th SSD*, 2004.

# Neutrons?

back side

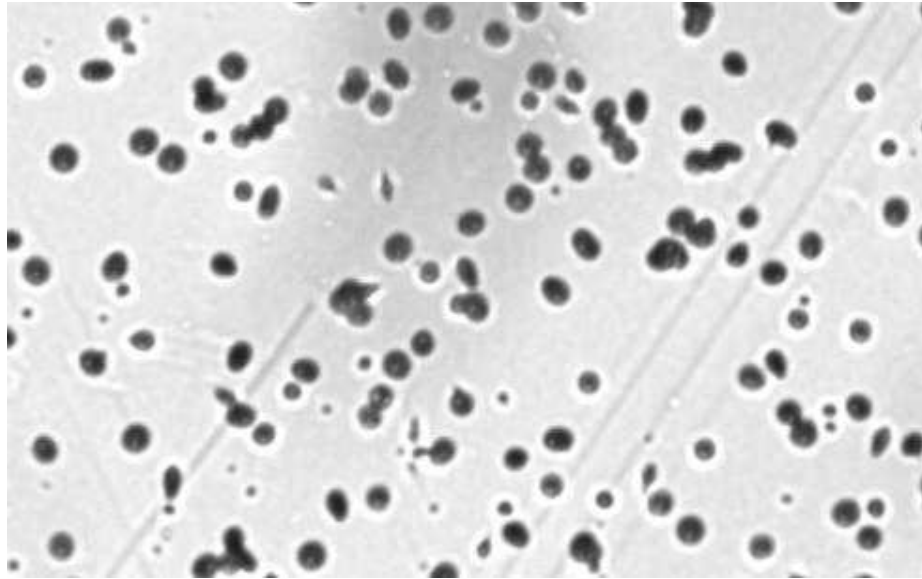

back, deeper focus

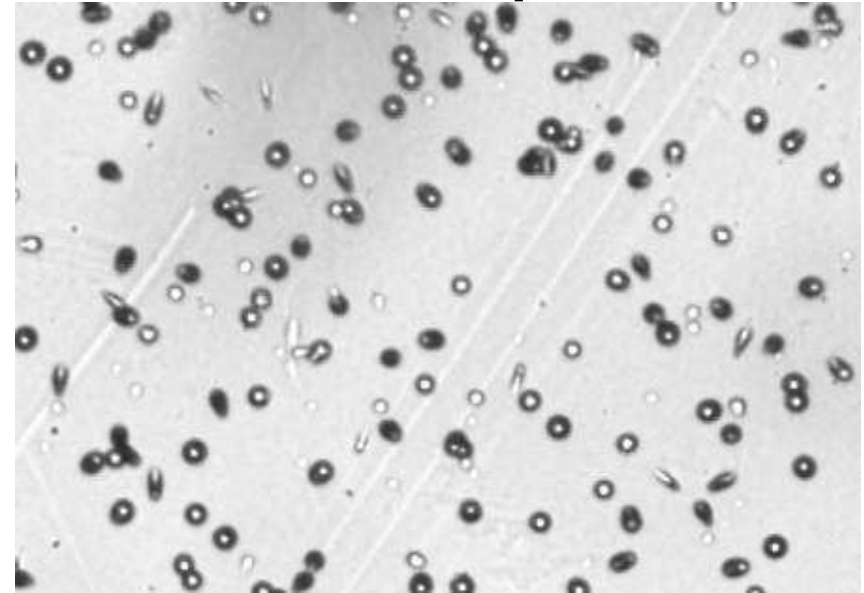

$^{238}\text{PuO}$  fission neutron source<sup>1</sup>

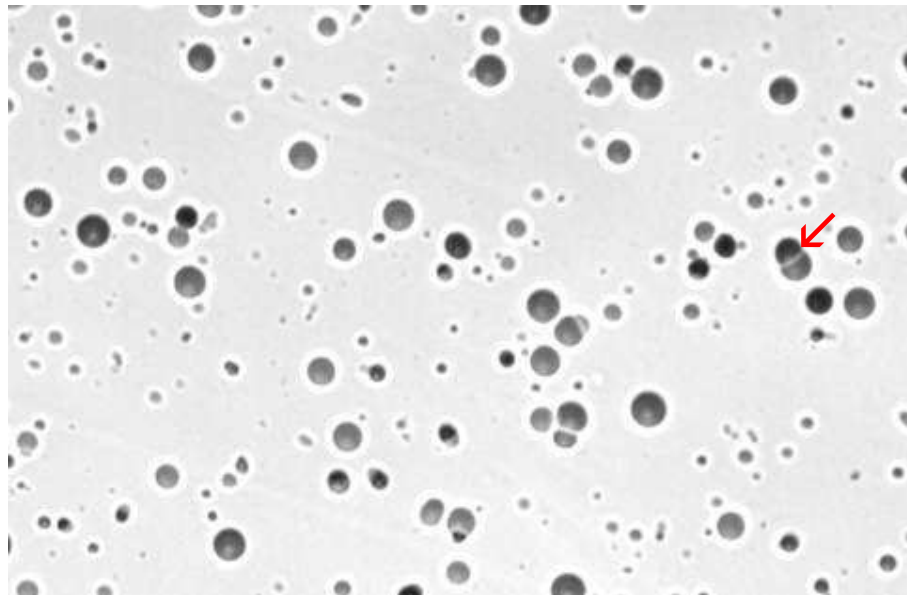

Note different size tracks and bright center at deeper focus.

If neutrons, further etching will expose new tracks, as shallower tracks disappear.

**Note double tracks.**

<sup>1</sup> Phillips, *et. al.*, "Neutron Spectrometry Using CR-39 Track Etch Detectors", *14th SSD*, 2004.

# Conclusions

- **Early Pd/D co-deposition experiments demonstrated excess enthalpy, formation of hot spots, emission of low intensity radiation, and production of tritium**
- **Excess enthalpy is generated by highly energetic fast reactions that resemble “mini-explosions”. This view is supported by IR imaging (hot spots) and by the response of the pressure/temperature sensitive substrates (piezoelectric material) onto which the Pd/D films are co-deposited**
- **An external electric/magnetic field changes the shape of the individual globules of the “cauliflower” structure of the Pd/D co-deposited material**
- **New elements are observed that are associated with the morphological features formed by the action of the external E/B fields**
- **Using CR-39 detectors, tracks are obtained that are consistent with both nuclear charged particles and neutron knock-on tracks**